



# Work Instruction: Install Defrost 2 Spd No Cab

## Defrost 2 Speed Heater No Cab (P/N 1202CUA00101N)

### WORK INSTRUCTION OVERVIEW

#### ⚠ DANGER

- Read and understand manual of die grinder before operating.
- Do not attempt to use this tool unless experienced to do so.
- Before starting die grinder, be sure that no one is in the plane of rotation.
- Always wear eye protection.
- Failure to observe these warnings could result in severe injury to yourself and or bystanders.

#### ⚠ WARNING

- DO NOT ATTEMPT THIS PROCEDURE IF YOU DO NOT HAVE PROPER TOOLS, TRAINING, AND FACILITIES.
- Read and follow all instructions provided when installing this product. Failure to do so may result in placing occupants at risk of serious injury or death.
- To protect bystanders and the service technician(s), shut vehicle off, remove the Ignition Key and secure vehicle to prevent unintended movement.
- Never operate the vehicle in excess of manufacturer's specifications.

#### NOTICE

- This accessory is **not** compatible with the ROXOR Full Hard Cab Enclosure or Vintage Heat and A/C Systems.
- Windshield removal is **required** for this installation, this includes removal of any accessory that would prevent windshield removal.

These instructions should be used for installing the Defrost for Dual Speed Heater Kit **only**.

- P/N 1202BUA00130N - Heater Kit (4 Hole)
- P/N 1202BUA00090N - Heater Kit (6 Hole)

### TOOLS REQUIRED









- |                   |                       |
|-------------------|-----------------------|
| • 10 mm Socket    | • Straight Edge       |
| • 13 mm Socket    | • Drill               |
| • T15 Torx        | • Die Grinder         |
| • T30 Torx        | • Cut Off Wheel       |
| • 19/64 Drill Bit | • Center Punch        |
| • 13 mm Wrench    | • Scissors            |
| • Socket Driver   | • Protective Eye-wear |

### TORQUE SPECIFICATION

Tighten each fastener to the torque specification below:

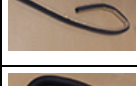
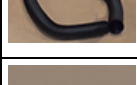
- **Pan Screws** – 2.5 N•m (±0.5 N•m)
- **M6 Screws** – 10 N•m (±1 N•m)
- **M8 Bolts** – 23.5 N•m (±3.5)

### COMPONENT TABLE

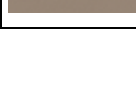
Kit Component	Description	Qty
	Defroster Duct - Lower Distribution PN - 1203ZUA00661N	1
	Register Cover P/N - 1203ZUA00441N	1
	Defrost Duct P/N - 1203ZUA00421N	1
	Register Ball Valve PN - 1203ZUA00641N	2
	Foam - Windshield to ROPS PN - 0107AUA00031N	1
	Defrost Hose - 3 ft PN - 1202CUA00071N	1
	Pan Screw - 4.2X1.41X25 T15 P/N - 0000AUA01961N	2
	M6 Plastic Rivet P/N - 0105ZAW00211N	1
	M4.2 U-Nut P/N - 0000AUA00391N	2
	Cable Tie Strap - 305 mm Long P/N - 0000AUA00461N	4



# Work Instruction: Install Defrost 2 Spd No Cab

## Defrost 2 Speed Heater No Cab (P/N 1202CUA00101N)

### INSTALLATION PROCEDURE

1. Remove (11) M6 T30 torx screws.



2. Carefully pry out steering column cover and tape to steering wheel.

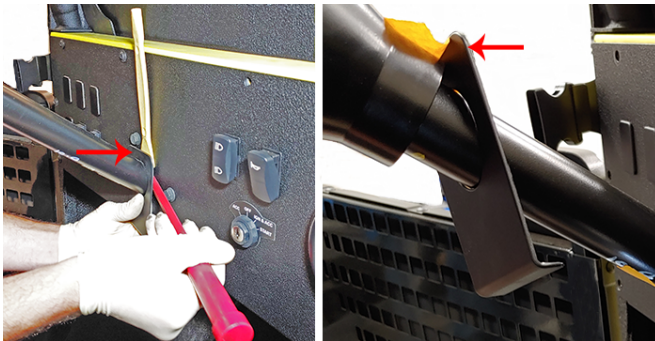

3. Remove (3) M8 bolts, tape cover and column, disconnect switches and remove instrument panel.

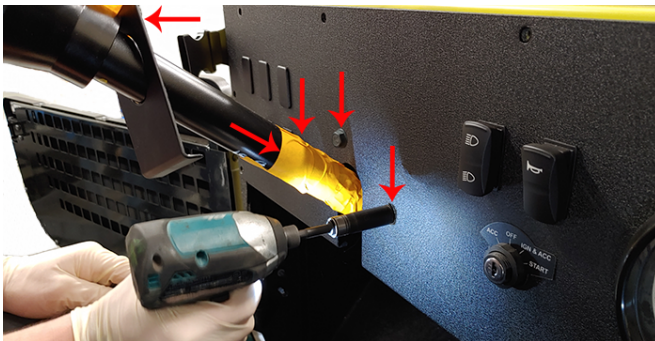

4. Using template, use suitable punch to mark (4) corners. Use (2) locator holes for centering.

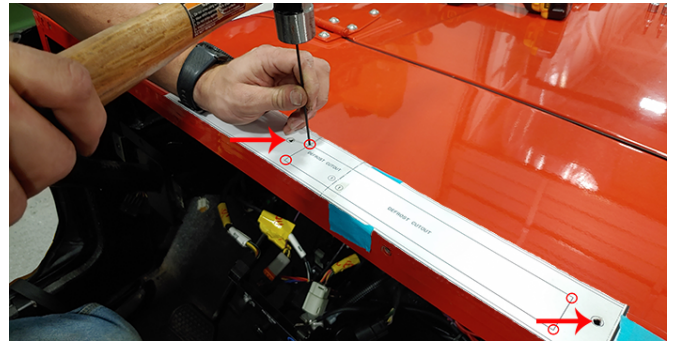

5. Using template, use center punch to mark (1) outer hole for register cover.



6. Use straight edge to draw rectangle using punch marks.

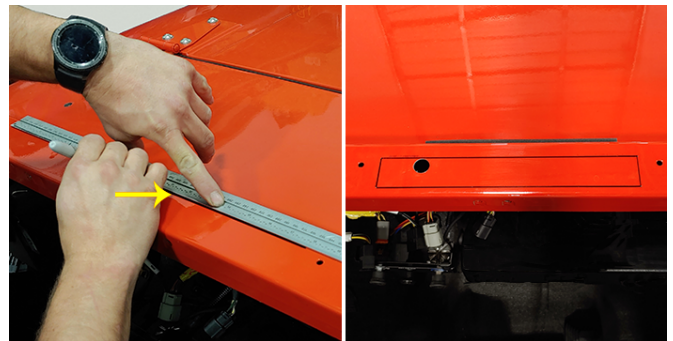

7. Score lines lightly, then cut out top layer.

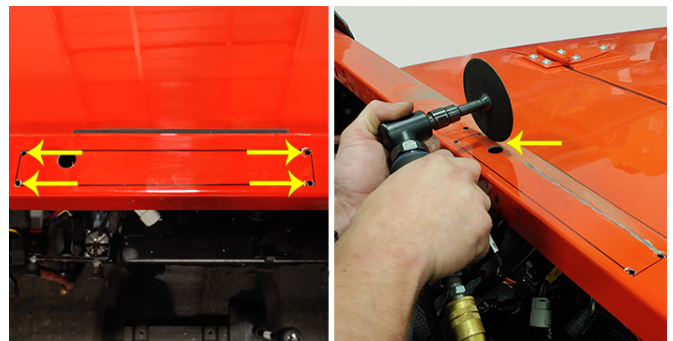



# Work Instruction: Install Defrost 2 Spd No Cab

## Defrost 2 Speed Heater No Cab (P/N 1202CUA00101N)

8. Cut out lower section. Check fitment and trim if needed.

**NOTICE** Deburr and paint all rough areas.



9. Using (2) u-clips, install duct upward with (1) pan head screw. Be sure it snaps into place, front to back.

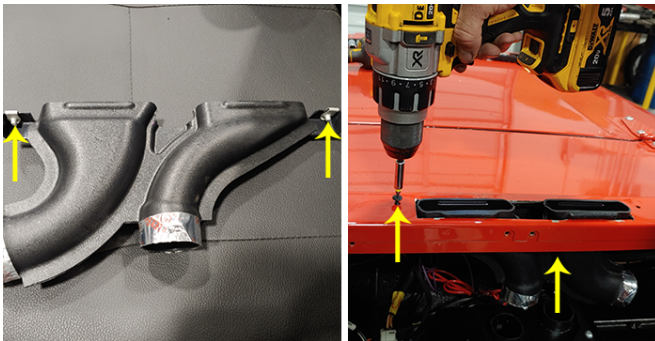

10. Measure 20" and cut defrost hose. Remaining section should be roughly 16". Left side will be longer side.



11. Affix foam around inside edge of lower distribution bowl.

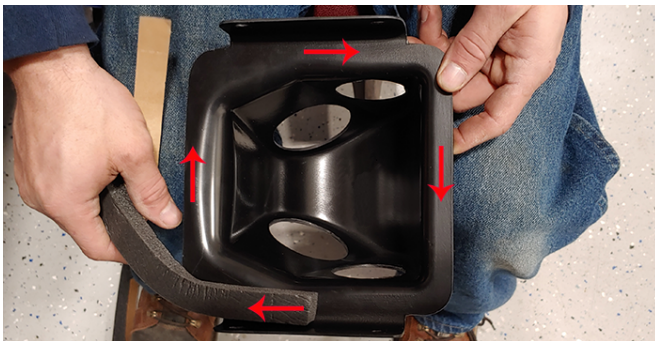

12. Separate (2) register ball valves and install into (1) lower distribution bowl.

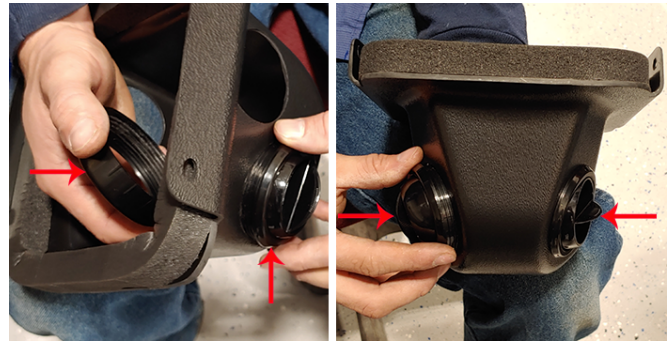

13. Remove lower (2) M6 hex bolts from heater. Repeat for opposite side of heater.

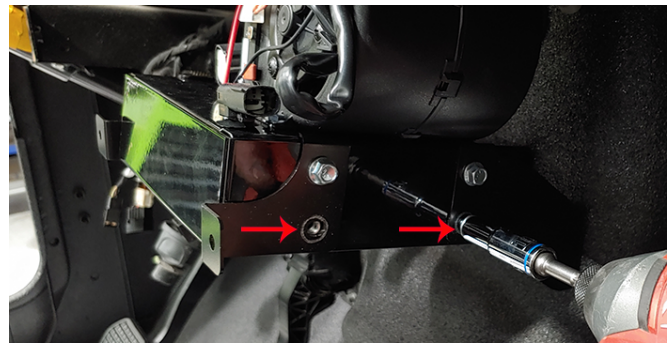

14. Install (1) lower distribution bowl re-using (4) M6 hex bolts.

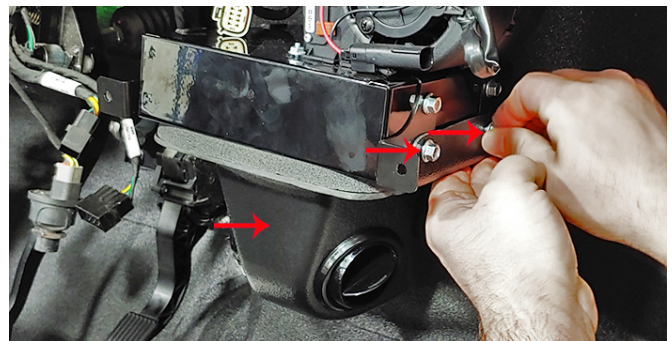

15. If equipped, cut out wiper grommet section on register cover.

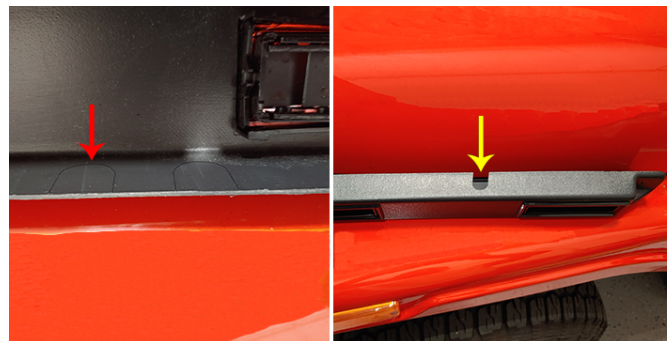



## Work Instruction: Install Defrost 2 Spd No Cab

### Defrost 2 Speed Heater No Cab (P/N 1202CUA00101N)

16. Re-install (3) M8 bolts, remove tape and re-install column cover.

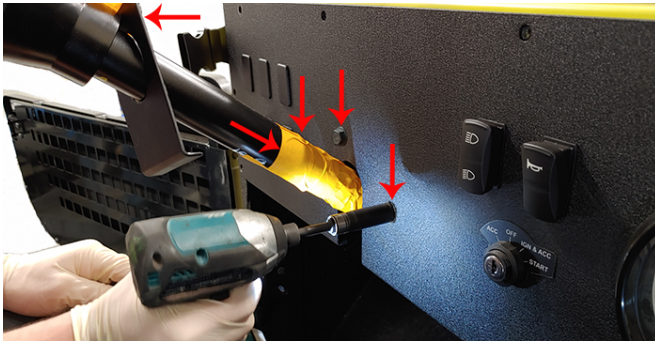

17. Using (1) M6 plastic rivet, (1) pan screw right, install register cover, then re-install remaining (2) M6 torx screws.



18. Re-using (11) M6 screws, connect all connectors and re-install IP.

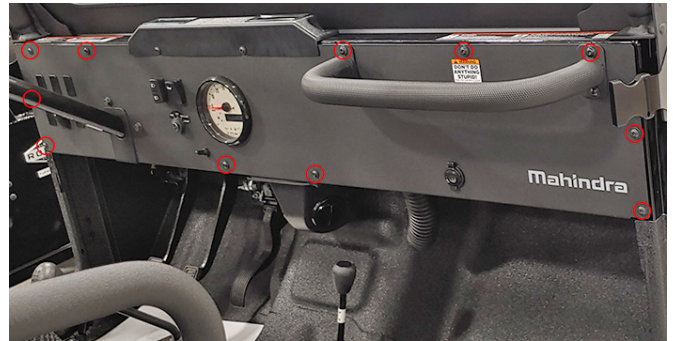

19. Install (2) hoses to distribution bowl.

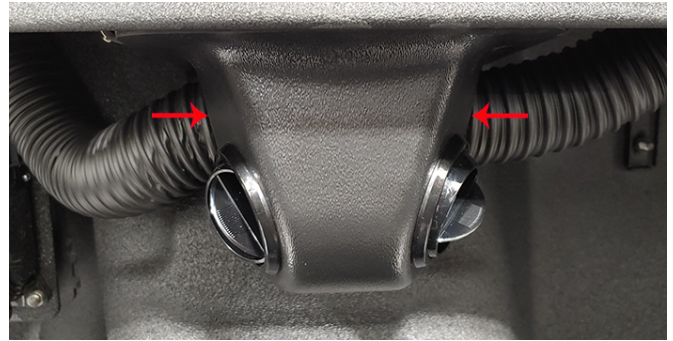

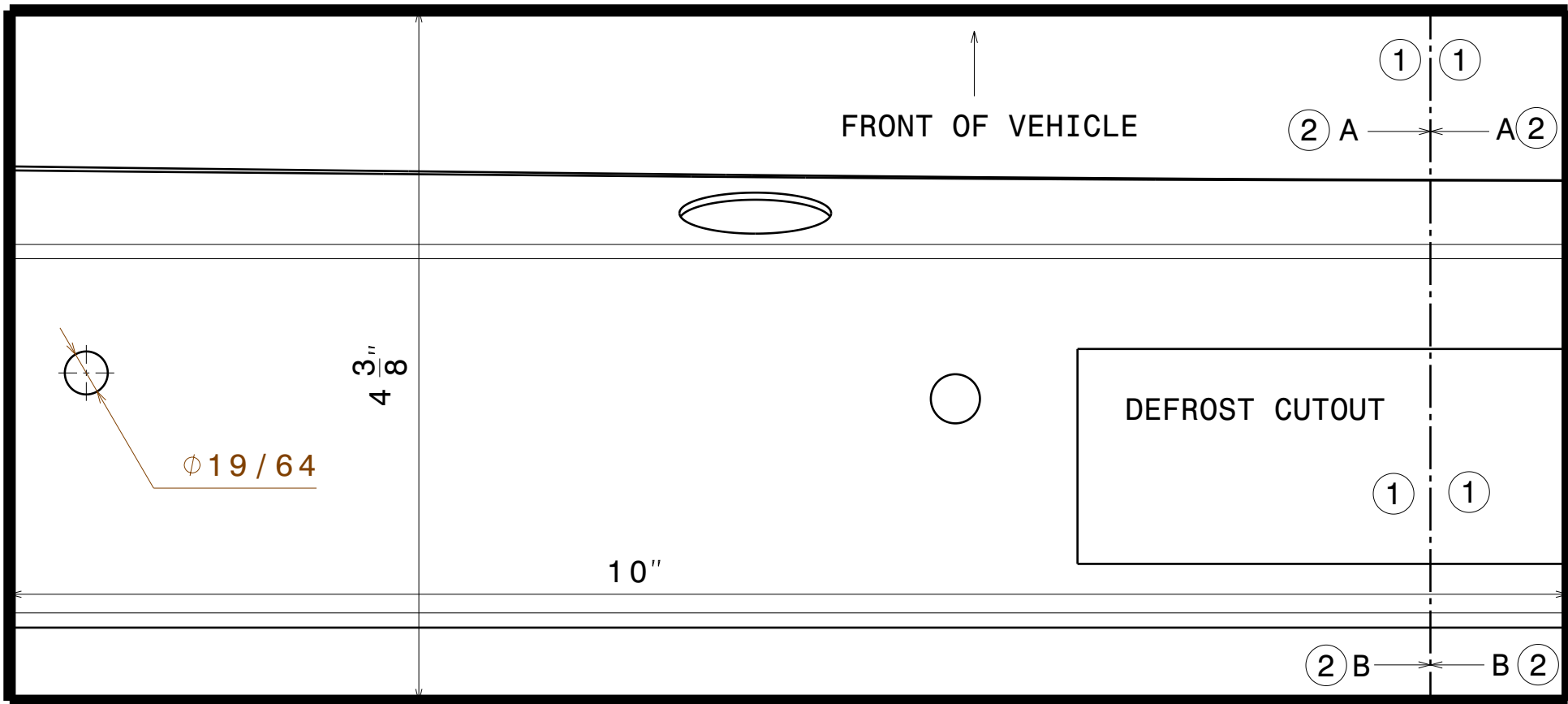

TEMPLATE 1 OF 2  
MUST BE USED WITH RH TEMPLATE

1203ZUA00601N

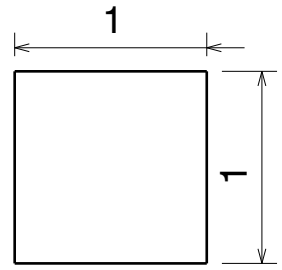

**LH TEMPLATE**

- 1: CUT ALONG LINE
- 2: ALIGN ARROWS A-A AND B-B
- 3: TAPE TOGETHER AFTER ALIGNING ARROWS

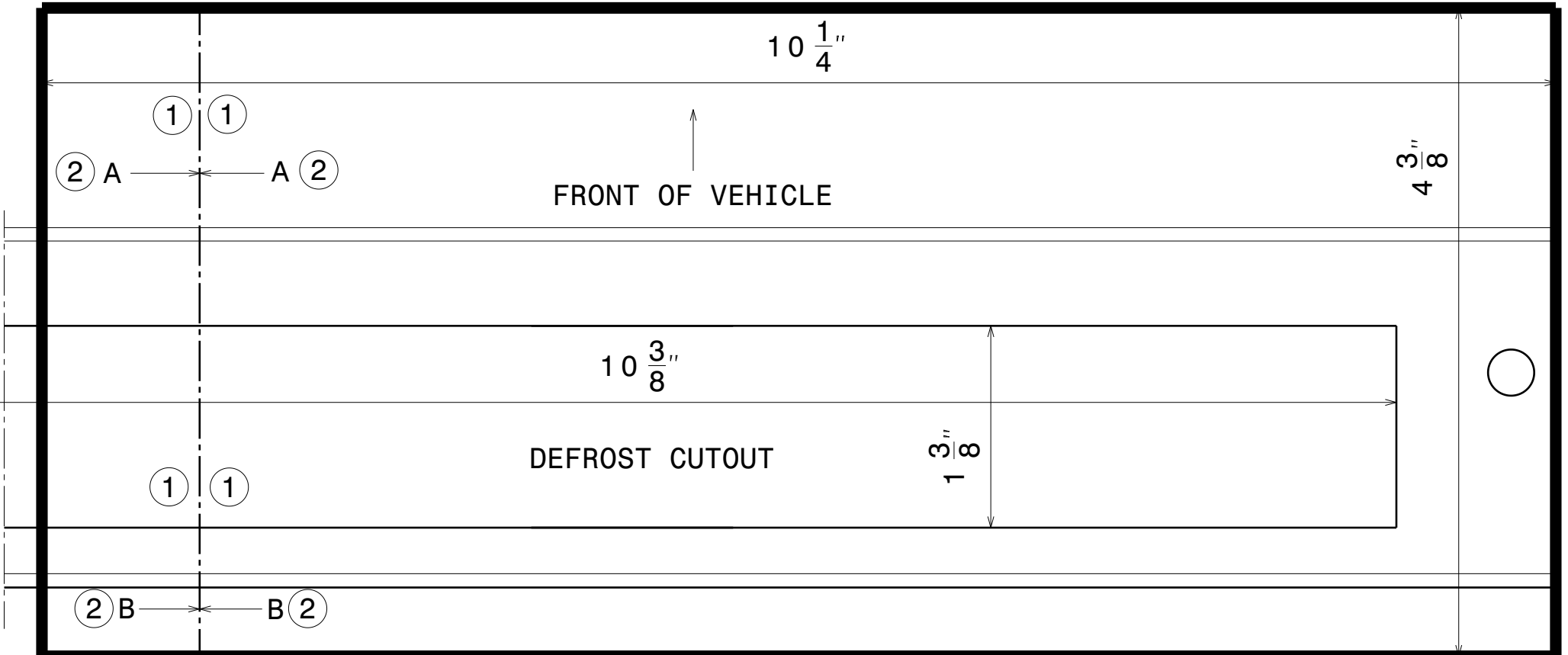

TEMPLATE 2 OF 2  
MUST BE USED WITH LH TEMPLATE

1203ZUA00601N

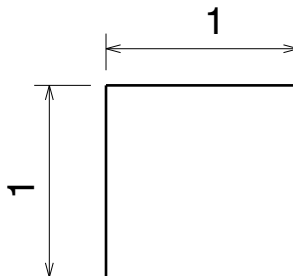

RH TEMPLATE

- 1: CUT ALONG LINE
- 2: ALIGN ARROWS A-A AND B-B
- 3: TAPE TOGETHER AFTER ALIGNING ARROWS